

DATE: _____
 JOB: _____
 ELEVATOR/FLOOR: _____
 OPERATOR/INTERLOCK: _____

INSTRUCTIONS: FILL ALL BLANKS, INDICATE DOOR HAND,
 INDICATE DOOR TOP TAP SIZE ($\frac{3}{8}$ -16, $\frac{1}{2}$ -13, M10, M12)
 ADVISE DOOR DRILLING TEMPLATE OR SKETCH

REVISIONS			
REV.	DESCRIPTION	DATE	APPROVED

NOTE:
 RIGHT HAND DOOR OPENING SHOWN
 LEFT HAND DOOR OPENING OPPOSITE

KEYWAY: REQUIRED? NOT REQUIRED? (.75)

**2 OR 4
 TAPPED
 HOLES?**

TAP SIZE:

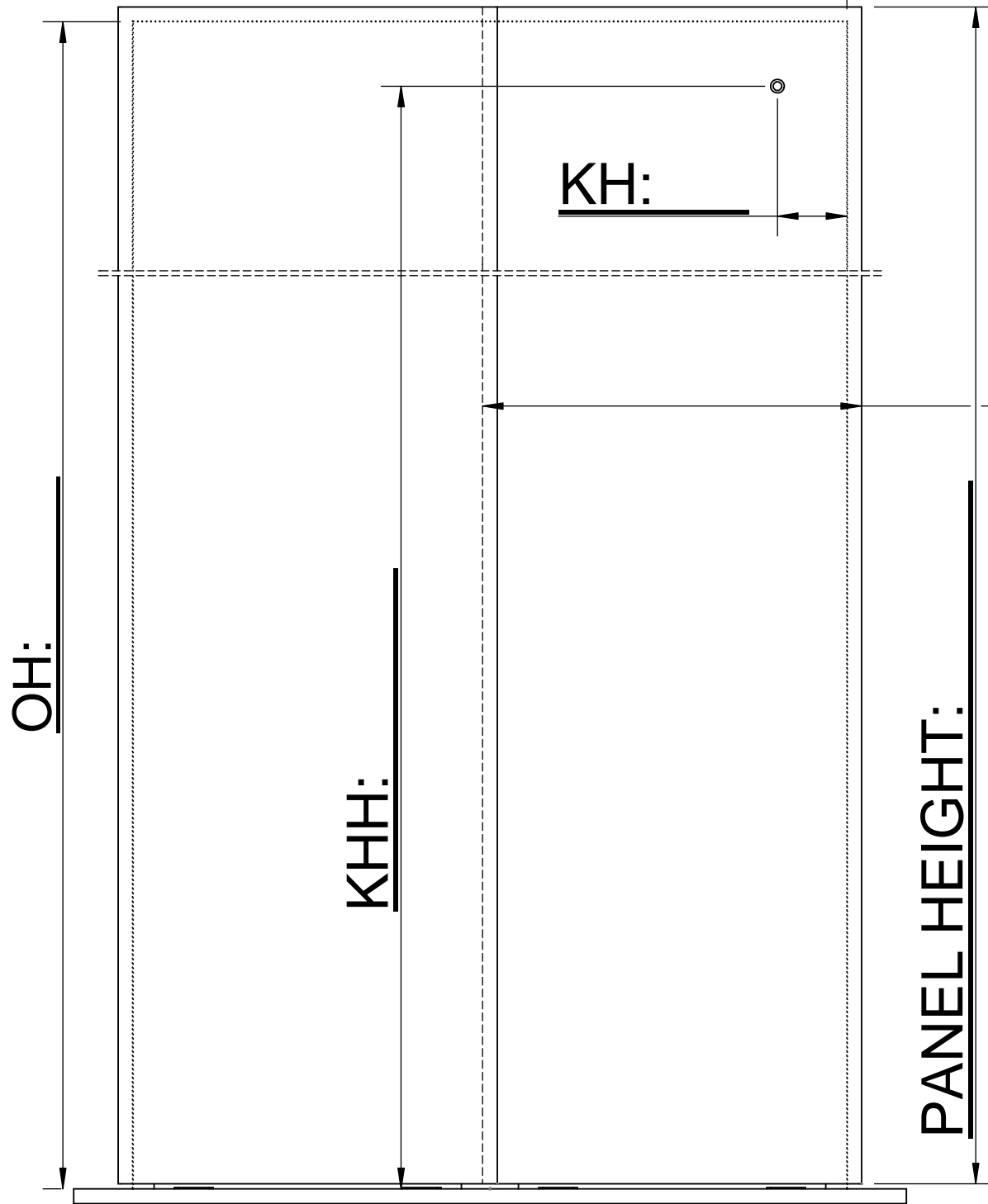

**PANEL
 WIDTH:**

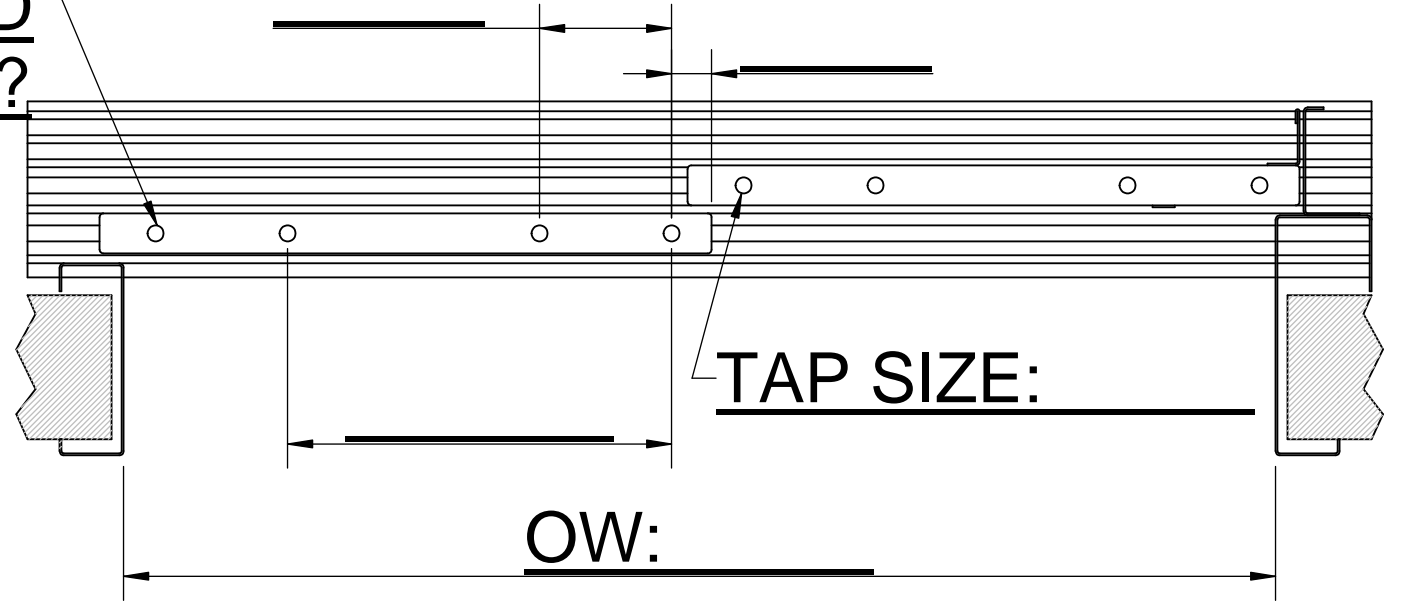

SILL TO DOOR:

DOOR THK:

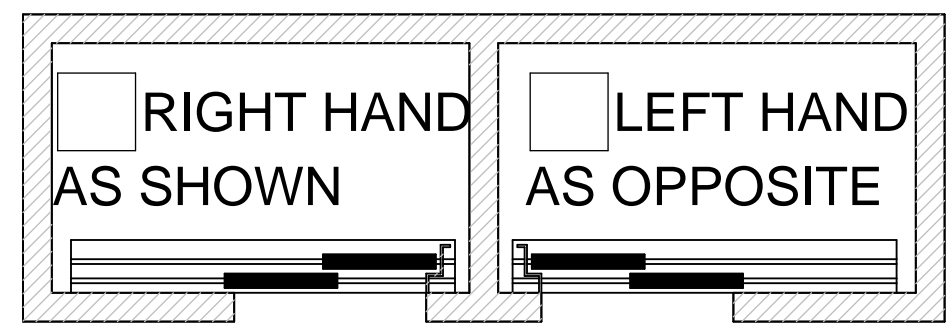

DOOR HAND

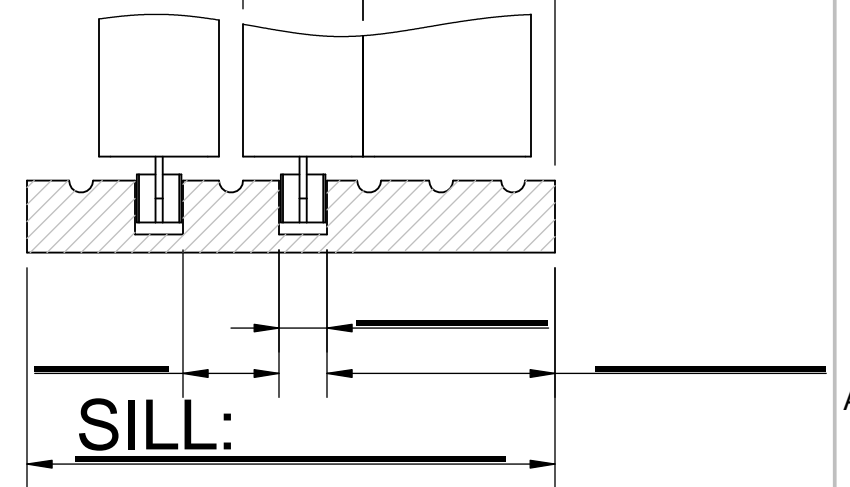

HALLSIDE ELEVATION (VIEW FROM HALLWAY)

****WARNING****
 PROPRIETARY INFORMATION
 REPRODUCTION AND/OR USE OF ALL OR
 ANY PART OF THIS (THESE) PAGE(S) OR
 THE INFORMATION HEREIN WITHOUT
 EXPRESS PERMISSION OF NORA
 NGUYEN AND/OR LEO TOMPERI IS
 STRICTLY PROHIBITED BY LAW.
 VIOLATORS WILL BE PROSECUTED
 DRAWN BY: LT DATE: 06.30.2023

UNLESS OTHERWISE SPECIFIED
 DIM ARE INCHES
 TOL ON LENGTH $\pm .05$
 HOLE DIA $\pm .01$ ANGLE $\pm 2^\circ$
 THIRD ANGLE PROJECTION

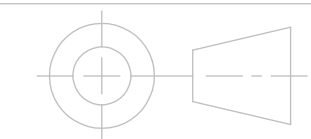

TITLE
 ENTRANCE/HATCH DOOR SURVEY

DWG NO: ENT-2S-SURVEY REV: _____